

FW-MAG1

FREEWAVE™ MAGNETIC CONTACT TRANSMITTER



CROW
ELECTRONIC ENGINEERING LTD.
INSTALLATION INSTRUCTIONS
P/N 7101407

OPERATION

The Wireless Magnetic detector transmits the following events data:

- SUPERVISION** - a periodical transmission. Every 12~14 min. indicates detector's presence.
- ALARM** - Alarm transmission triggered by magnet removal (door/window open/close).
- LOW BAT** - Whenever the battery reaches a pre-set low level (~2.4V) Battery Low signal will be sent with the nearest message (Supervisor, Alarm, etc.).
- TAMPER** - Whenever the FW-MAG cover is removed or the unit's cover is put back, a message will be transmitted with "Tamper" signal.

MOUNTING THE DETECTOR

1. To remove the front cover, unscrew the holding screw, insert a flat screwdriver in the slot between the front and the bottom and push gently, until the front cover is disengaged and the opening click is heard.(Fig. 1)
2. Remove the PC board.
3. Break out the desired holes for proper installation.(Fig. 2)
4. Mount the detector base.
5. Mount the Magnet Unit near the Marking.
6. Reinstall the PC board.
7. Perform Reset procedure.
Before battery replacement capacitors discharge must be done - use flat screwdriver to make momentary short circuit for JP1 pins (Fig. 3)
8. Install battery in the battery holder according polarity .

INSTALLATION

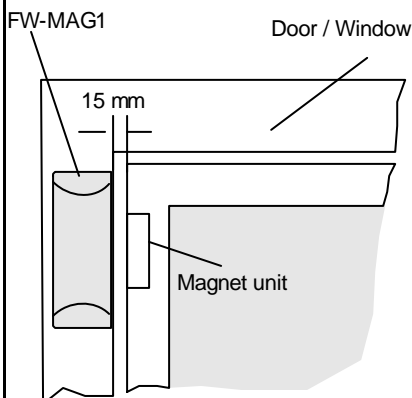

INTRODUCTION

The FW-MAG1 as a part of the FREEWAVE wireless security system is an advanced, fully supervised low-current magnetic contact transmitter.

The FW-MAG1 includes built-in reed switch and wired input for external reed switch.

The FW-MAG1 is powered by an internal, long life Lithium battery.

Each FW-MAG1 has a unique ID code (24bit). Compatible FreeWave receivers are designed to "learn" the specific ID of FW-MAG1 detectors and respond only to them.

Alarm due to contact open/close and other data are forwarded to the control panel for specific event indication.

A periodic test transmission for supervision purposes takes place automatically once in 12 min ~ 14 min. The receiver is informed that the FW-MAG1 detector is taking an active part in the

SELECT MOUNTING LOCATION

It is recommended to mount MAG vertically and on flat area to get maximum range.

As the detector is a wireless transmitter, and in order to take full advantage of it's sophisticated operation, do not install the detector in areas where large metal objects could interfere with the transmission of signals.

It is recommended to attach transmitter to the fixed frame and the magnet to the movable part (door or window), as shown in page 10.

For detector installation it is recommended to use SCREW WOOD 3x30 PH. FLAT HEAD
CAUTION: using different or bigger screws can damage the electronic board.

FIG. 2 - KNOCKOUT HOLES

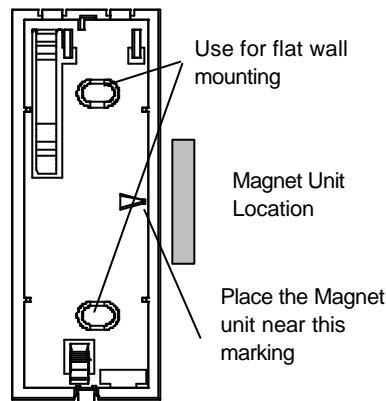

RSSI - RF SIGNAL INDICATION

The FREEWAVE control panel has "RF Signal quality Indication" for each transmitter in order to help the installer define best location for the detector from RF point of view. The indication value is between 1 and 100, where 100 is the best RF received signal. If the RSSI indication is less than 30, it is a sign for weak RF link, try to find a better installation for the MAG.

NOTE:
See FREEWAVE control panel installation instruction.

FEATURES

- State-of-the-art wireless security system
- Low current Technology
- Powered by a 3.6Volt Lithium battery
- Battery life : up to 4 years
- Frequency Band: 868MHz, 433MHz
- Contact Open transmission
- Contact Close transmission
- Tamper Changed transmission
- Supervision transmission
- Battery condition signal transmission
- Range up to 1 km at free space.
- Unique ID number

FIG. 1 - REMOVAL OF FRONT COVER

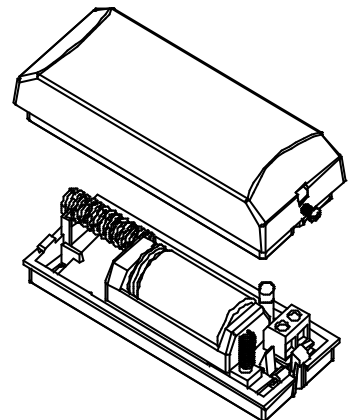
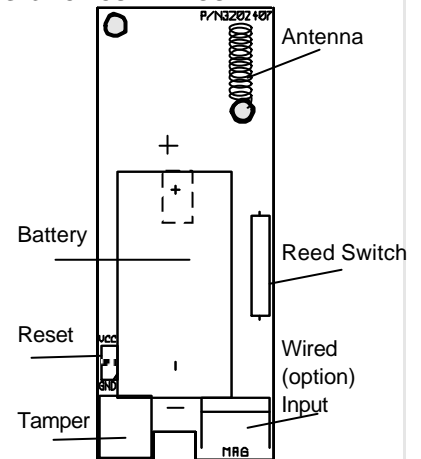

FIG. 3 - CIRCUIT LAYOUT



ID REGISTRATION - "LEARN" PROCEDURE

Refer to the system receiver's installation instructions and follow the procedure given there for "learning" detector IDs. Perform transmission by pressing and releasing tamper switch for learning it by FREEWAVE control panel receiver. Make sure that the receiver is at learning mode - according to control panel installation instruction.

NOTE:
It is recommended to power up the detector and let the system receiver "learn" the detector's ID before actual installation.

ALARM TRANSMISSION TEST

Removing and placing of magnet unit enables the alarm transmission test feature. Check that the receiver unit indicates at least 2 events – one for removing and one for placing the magnet.

To check this function it is necessary to verify that the FREEWAVE control panel display shows the following message

Zone # X Open

while removing the magnet unit, and the message disappear while placing the magnet back (X = zone number from which the message received)

16

TAMPER TRANSMISSION TEST

Pressing and releasing the tamper (push button) enables the TAMPER transmission test feature. Check that the receiver unit indicates at least 2 events – one for pressing and one for releasing. Verify on the FREEWAVE control panel that display shows

Trouble Zone #

17

TRANSMISSION RANGE TEST

By Alarm transmission test (Changing Magnet position) it's enable to check the RF transmission quality (RSSI). Special indication at the control panel displays continuously the received RF signal quality. See page 11 and FREEWAVE control panel installation instruction.

18

BATTERY

A 3.6 V lithium battery powers the unit. If the battery reaches a factory preset low level, the LOW BATTERY signal will be sent and from this moment the detector remains operational for another 30 days giving enough time to replace the 3.6V lithium battery.

19

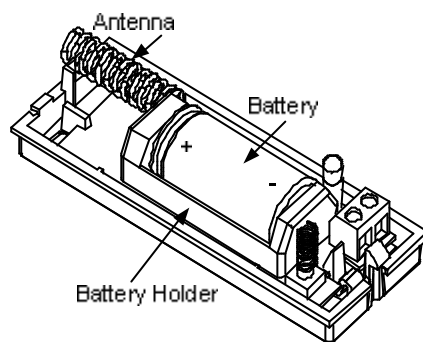
BATTERY PLACEMENT

20

BATTERY REPLACEMENT

- Remove the front cover by inserting a flat screwdriver in the appropriate slot.
- Take out the old battery.
- Before battery replacement capacitors discharge must be done. Use flat screwdriver to make momentary short circuit on JP1 pins. (see Fig.3)
- Install a new battery according polarity.

21

The battery must be replaced by:

XL-050F Size: 1/2AA

3.6V Lithium Battery

Models as: XL-050F ENERGY

LS14250 SAFT

TL-5902 TADIRAN

22

CAUTION !!!

RISK OF EXPLOSION IF BATTERY IS REPLACED BY AN INCORRECT TYPE.

DISPOSE OF USED BATTERIES ACCORDING TO THE INSTRUCTIONS.

23

This device complies with:

European Council Directive EMC

89/336/EEC

EN50130-4

EN301489

EN300220

EN50081.

SAFETY 73/23/EEC

EN60950 (ITE)

24

TECHNICAL SPECIFICATIONS

Data Protocol	FreeWave
Modulation Type	FSK (1 Frequency)
Frequency band	868MHz / 433MHz
Identification	Unique ID serial number – 24 bit
Event Transmission	Alarm, Tamper, Supervision, Low Bat
Supervision Timing	12–14 minutes (random)
Detection Method	Internal Reed Switch or External Device
Magnet	up to 1km
Range in open space	Lithium. 3.6V Type: XL-050F Size:
Battery	1/2AA
Current Consumption	
Standby	~5 µA
Transmission	~16 mA
Tamper Switch	On Front Cover Removal; Back Tamper (Option)
Operating temperature	
Range	-10°C to +50°C
Dimensions	87mm x 35mm x 24mm
Weight (inc. battery)	40 gr

CROW LIMITED WARRANTY

(Crow) warrants this product to be free from defects in materials and workmanship under normal use and service for a period of one year from the last day of the week and year whose numbers are printed on the printed circuit board inside this product.

Crow's obligation is limited to repairing or replacing this product, at its option, free of charge for materials or labor, if it is proved to be defective in materials or workmanship under normal use and service. Crow shall have no obligation under this Limited Warranty or otherwise if the product is altered or improperly repaired or serviced by anyone other than Crow.

There are no warranties, expressed or implied, of merchantability or fitness for a particular purpose or otherwise, which extend beyond the description on the face hereof. In no case shall Crow be liable to anyone for any consequential or incidental damages for breach of this or any other warranty, expressed or implied, or upon any other basis of liability whatsoever, even if the loss or damage is caused by Crow's own negligence or fault.

Crow does not represent that this product can not be compromised or circumvented; that this product will prevent any person injury or property loss or damage by burglary, robbery, fire or otherwise; or that this product will in all cases provide adequate warning or protection. Purchaser understands that a properly installed and maintained product can only reduce the risk of burglary, robbery or other events occurring without providing an alarm, but it is not insurance or a guarantee that such will not occur or that there will be no personal injury or property loss or damage as a result. Consequently, Crow shall have no liability for any personal injury, property damage or any other loss based on claim that this product failed to give any warning. However, if Crow is held liable, whether directly or indirectly, for any loss or damage arising under this limited warranty or otherwise, regardless of cause or origin, Crow's maximum liability shall not in any case exceed the purchase price of this product, which shall be the complete and exclusive remedy against Crow.

CROW ELECTRONIC ENGINEERING LTD.	57 Hamelacha St., Holon 58855
ISRAEL:	Tel: 972-3-5599307 / 8 / 9 Fax: 972-3-5592981 E-mail: support@crow.co.il
USA:	2160 North Central Road, Fort Lee, N.J. 07024 Tel: 1-800-GET CROW or (201) 944 0035 Fax: (201) 944 1199 E-mail: crow@emsusa.net
AUSTRALIA:	429 Nepean HWY Brighton East Vic 3187 Tel: 61-3-9596 7222 Fax: 61-3-9596 0888 E-mail: crow@crowaustr.com.au
POLAND:	VIDICON 01-231 Warszawa Ul. Plocka 17 Tel: 48 22 562 3000 Fax: 48 22 562 3030 E-mail: vidicon@crow.pl
LATIN AMERICA:	CROW LATIN AMERICA 5753 NW 151 st Street MIAMI LAKES, FL 33014 – USA Tel: +1-305-823-8700 Fax: +1-305-823-8711 E-mail: sales@crowlatinamerica.com
ITALY:	DEATRONIC VIA Giulianello 4/14 00178 ROMA, ITALY Tel: +39-0676-12912 Fax: +39-0676-12601 E-mail: info@deatronic.com

These instructions supersede all previous issues in circulation prior to January 2003.